

Double Eccentric Cargo Oil Lug Type

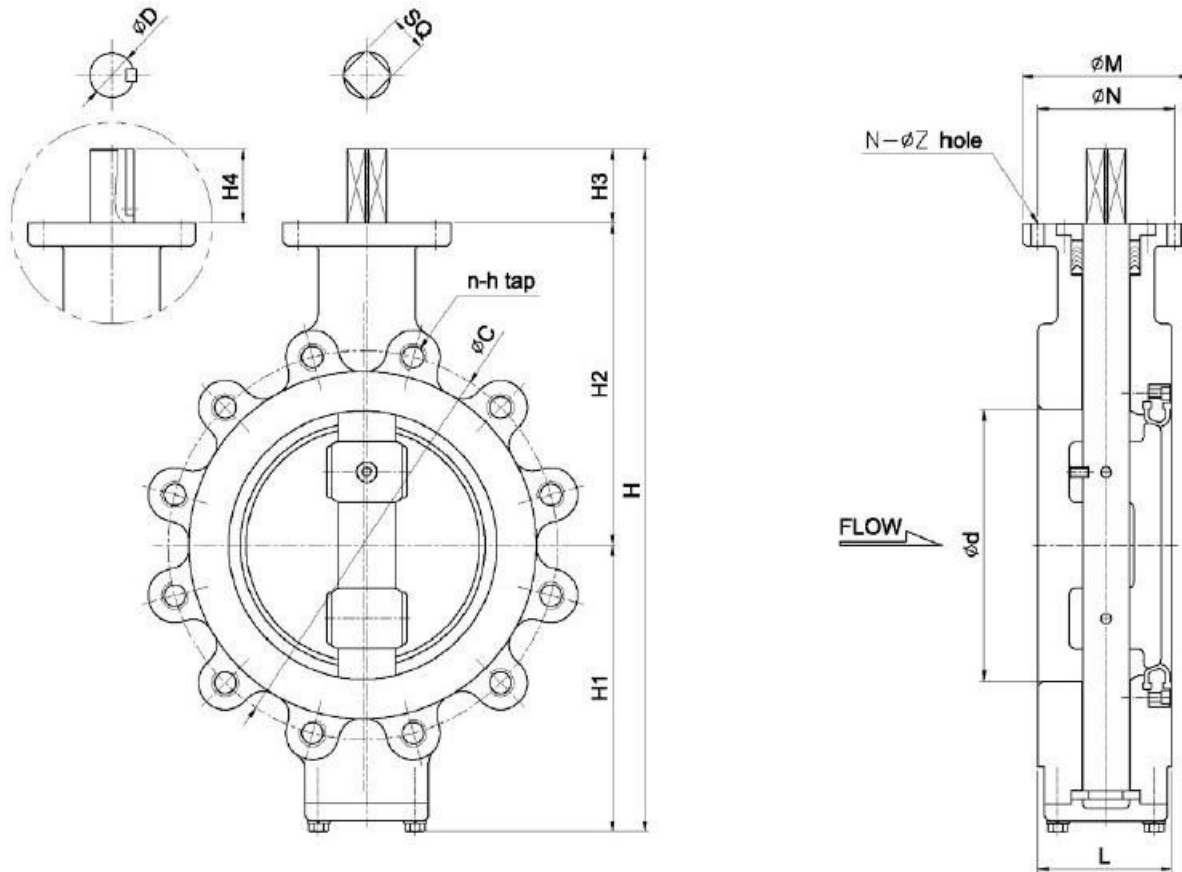

VALVE DIMENSIONS

unit : mm

SIZE		ød	L	H	H1	H2	H3	STEM			TOP FLANGE			WEIGHT (APPROX.) (kg)		
inch	mm							SQ	ROUND		TYPE	øN	øM		N-øZ	
									øD	H4						KEY
2"	50A	62	44	276	113	130	33	12	16	33	5 x 5	F07	70	90	4 - 9	7.5
2.5"	65A	75	46	266	118	135	33	12	16	33	5 x 5	F07	70	90	4 - 9	9.0
3"	80A	90	62	300	127	140	33	12	19	33	6 x 6	F07	70	90	4 - 9	11.0
4"	100A	106	65	339	146	160	33	12	19	33	6 x 6	F07	70	90	4 - 9	15.0
5"	125A	128	70	407	162	190	55	17	22	55	8 x 7	F10	102	125	4 - 12	20.0
6"	150A	150	90	459	189	215	55	17	25	55	8 x 7	F10	102	125	4 - 12	29.5
8"	200A	202	100	509	214	240	55	27	32	55	10 x 8	F10	102	125	4 - 12	42.0
10"	250A	250	110	606	256	285	65	27	40	65	12 x 8	F14	140	175	4 - 18	60.0
12"	300A	300	110	655	275	315	65	27	40	65	12 x 8	F14	140	175	4 - 18	75.0
14"	350A	335	120	749	309	350	90	36	50	90	14 x 9	F16	165	210	4 - 22	87.0
16"	400A	390	130	820	350	380	90	36	50	90	14 x 9	F16	165	210	4 - 22	125.0
18"	450A	440	150	890	383	417	90	46	55	90	16 x 10	F16	165	210	4 - 22	159.0
20"	500A	490	160	955	420	445	90	50	65	90	20 x 12	F16	165	210	4 - 22	200.0
22"	550A	540	170	1021	454	477	90	50	70	90	20 x 12	F16	165	210	4 - 22	280.0
24"	600A	594	200	1128	488	520	120	50	80	120	22 x 14	F25	254	300	8 - 18	345.0
26"	650A	644	210	1178	513	545	120	-	80	120	22 x 14	F25	254	300	8 - 18	410.0
28"	700A	700	220	1262	552	590	120	-	80	120	22 x 14	F25	254	300	8 - 18	520.0
30"	750A	750	230	1333	583	620	130	-	85	130	22 x 14	F30	298	350	8 - 23	675.0
32"	800A	800	240	1410	625	655	130	-	90	130	25 x 14	F30	298	350	8 - 23	795.0
34"	850A	850	240	1470	655	685	130	-	95	130	25 x 14	F30	298	350	8 - 23	900.0
36"	900A	900	240	1585	690	735	160	-	100	160	28 x 16	F35	356	415	8 - 33	1100.0
40"	1000A	1000	240	1725	760	805	160	-	110	160	32 x 18	F35	356	415	8 - 33	1250.0